

CONCORD **SCOUT**

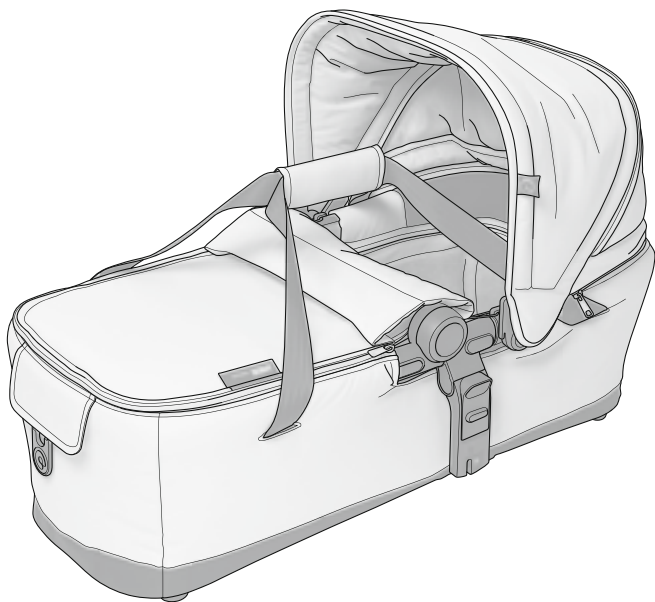

DEUTSCH	03
ENGLISH	13
FRANÇAIS	23
ESPAÑOL	33
ITALIANO	43
PORTUGUÊS	53
NEDERLANDS	63
NORSK	73
DANSK	83
SUOMI	93

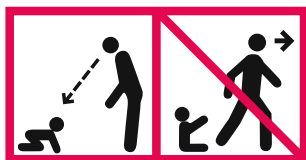

Norm DIN EN 1888:2012

Norm DIN EN 1466:2014

standard DIN EN 1888:2012

standard DIN EN 1466:2014

norme DIN EN 1888:2012

norme DIN EN 1466:2014

norma DIN EN 1888:2012

norma DIN EN 1466:2014

szabvány DIN EN 1888:2012

szabvány DIN EN 1466:2014

_ ENGLISH

OVERVIEW	14
WARNINGS	14
UNFOLDING	16
FOLDING SHUT	17
USING THE SUN SHADE	18
OPENING THE FOOT SECTION	19
USING THE WIND PROTECTOR	19
SECURING ONTO A CONCORD BUGGY	20
GUARANTEE	21
CLEANING INFORMATION	22
CONCORD ORIGINAL SPARE PARTS/ACCESSORIES	22

_ THANK YOU!

We are delighted that you have chosen a quality Concord product. You are sure to be convinced by this product's versatility and safety. We hope you enjoy using your new CONCORD SCOUT folding carrycot.

_ OVERVIEW

01 Securing strap

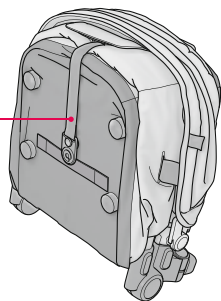

02 Sun shade

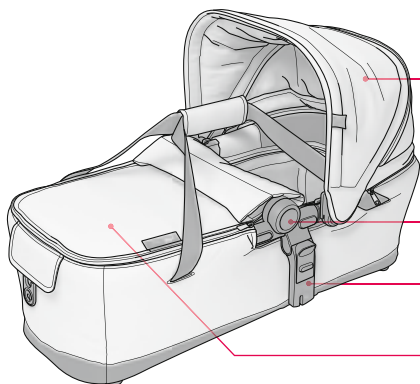

03 Release button

04 ProFix system adapter

05 Foot section top cover

_ WARNINGS

IMPORTANT

- Read the instructions carefully before use and keep for future reference.

Not following the instructions described here can impair the child's safety.

WARNING

- WARNING! This product is only suitable for a child who cannot sit up unaided.
- Never leave your child unattended.
- WARNING! Do not let other children play unattended near the carry cot.
- WARNING! Never use this product on a stand.
- Before use, ensure that all locking mechanisms are locked.
- WARNING: Do not add an extra mattress pad.
- WARNING! Only use on a firm, horizontal level and dry surface.
- WARNING! Do not use if any part of the carry cot is broken, torn or missing.
- Only use original Concord accessories.
- Be aware of the risks presented by an open fire and other heat sources such as electric heaters, gas flames etc. if they are in the immediate vicinity of the CONCORD SCOUT folding carrycot.
- Check the carrying straps, securing straps and the base of the CONCORD SCOUT folding carrycot regularly for damage and signs of wear and tear.
- Dispose of the plastic packaging immediately. It can endanger the lives of children.
- This product is suitable for a child who cannot sit up by itself, roll over and cannot push itself up on its hands and knees.
Maximum weight of the child: 9 kg.
- WARNING! Do not leave flexible carrying handles inside the carry cot.
- Check that the child's head is in a higher position than the rest of the child's body.

_ UNFOLDING

Place the CONCORD SCOUT folding carrycot on the floor. Fold out the ProFix system adapters (04). Release the securing straps (01) so that the side walls unfold completely.

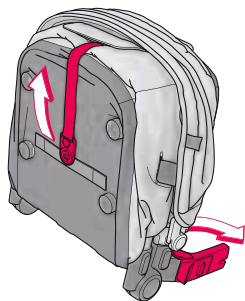

Press the release buttons (03) on the central hinge. Move the tubular frame of the CONCORD SCOUT folding carrycot apart at the top edge, and pull the central hinge upwards until it engages audibly on both sides.

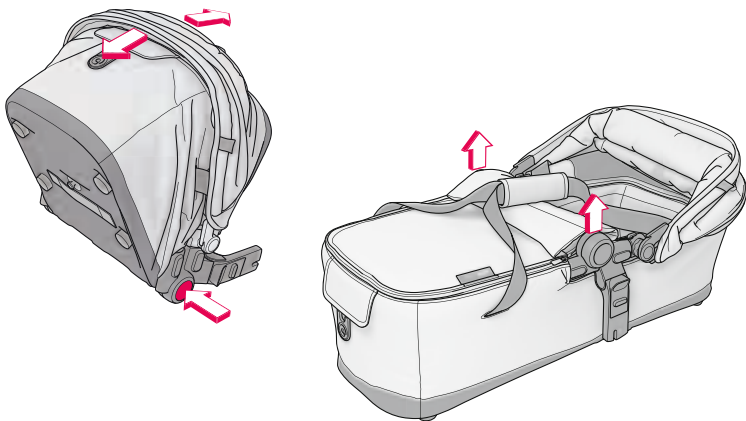

_ FOLDING SHUT

Fold down the sun shade (02) on the CONCORD SCOUT folding carrycot. Close the foot section top cover (05) and lay the carrying straps on it. Press the release buttons (03) and move the central hinge downwards. Fold the tubular frame of the CONCORD SCOUT folding carrycot together until it engages audibly.

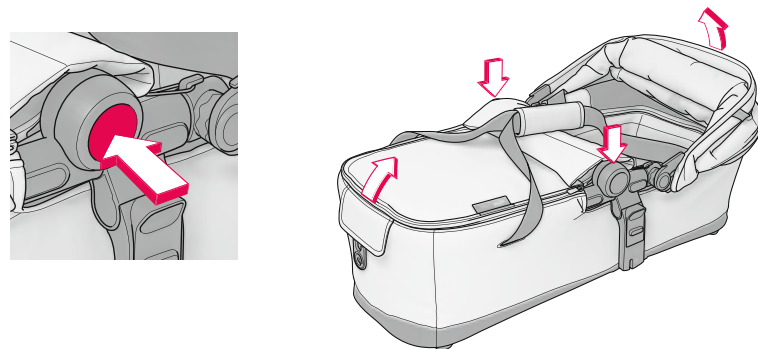

Pull the securing straps (01) upwards and out, and anchor them to the points provided on the bottom. Fold the ProFix system adapters (04) inwards.

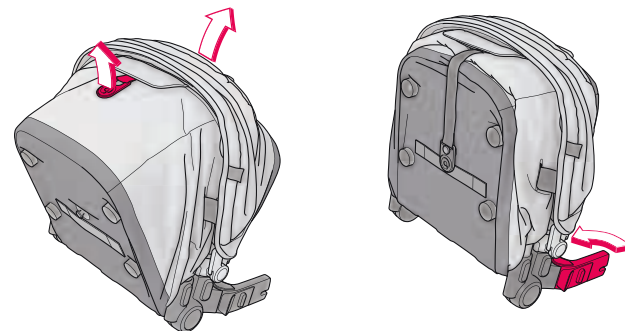

_ USING THE SUN SHADE

The sun shade (02) on the CONCORD SCOUT folding carrycot can be folded up and down or else removed completely. To remove the sun shade, undo the zip between the sun shade and the folding carrycot. Then pull the sun shade adapters out and away from the tubular frame.

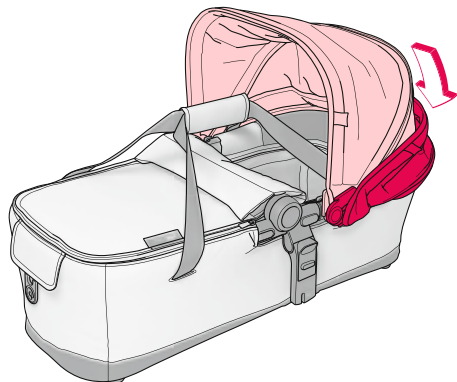

To mount the sun shade (02) on the CONCORD SCOUT folding carrycot, lay the carrying straps across the foot section. Position the sun shade adapters on the tubular frame next to the central hinge, and then attach the sunshade to the folding carrycot using the zip.

_ OPENING THE FOOT SECTION

To open the foot section of the CONCORD SCOUT folding carrycot, release the securing clips on the sun shade adapters. Pull the zip on the foot section back to the required position, and fold back the foot section top cover (05). The zip needs to be unzipped completely in order to remove the top cover.

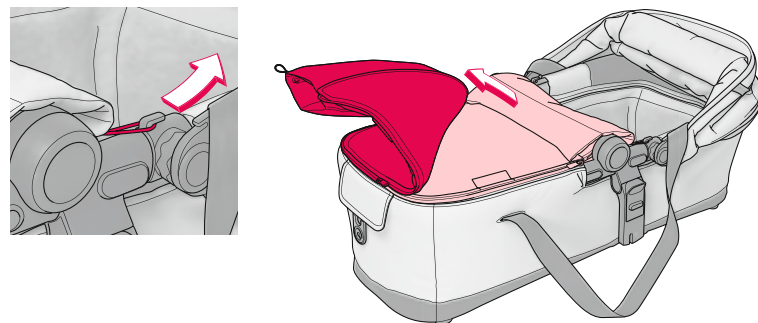

_ USING THE WIND PROTECTOR

To set up the wind protector on the CONCORD SCOUT folding carrycot, undo the press studs on the top of the foot section (05). Then slide the wind protector towards the head section and fasten it to the press studs provided.

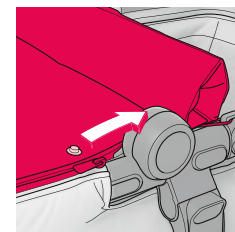

_ SECURING ONTO A CONCORD BUGGY

To secure the CONCORD SCOUT folding carrycot to a chassis, position the carrycot such that the child's head is facing forwards (in the direction of travel) and insert the adapters (04) into the receivers provided on the chassis, ensuring that they engage audibly.

WARNING

- Before use, ensure that all locking mechanisms are locked.

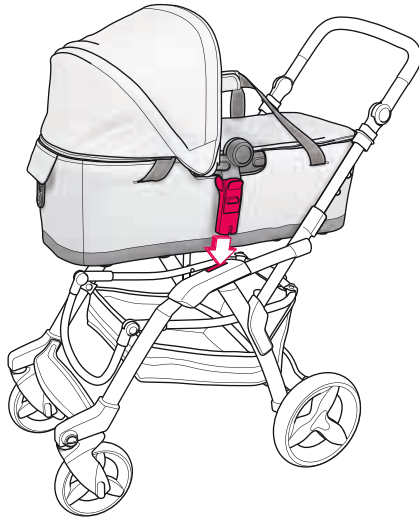

To release the folding carrycot from the fastenings, pull the release buttons on the adapters (04) upwards and lift the CONCORD SCOUT folding carrycot upwards and away from the chassis.

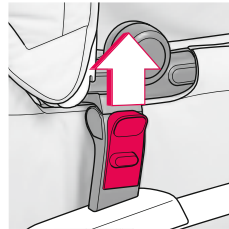

_ GUARANTEE

The guarantee begins on the day of purchase. The guarantee period corresponds to the statutory warranty period in the end-user's country concerned. At the manufacturer's discretion, the guarantee shall cover rectification, replacement or a price reduction.

The guarantee is valid for the original purchaser only. In the event of any defect, claims can not be considered unless the specialist dealer is notified of the fault as soon as it occurs for the first time. If the specialist dealer is unable to remedy the problem himself, he must return the product to the manufacturers together with details of the complaint, official proof of purchase and the purchase date. The manufacturers assume no liability for faulty goods that they did not supply.

The guarantee does not apply where:

- the product has been modified;
- the product is not brought back to the specialist dealer complete with proof of purchase within 14 days of the defect occurring;
- the defect was caused by improper usage or maintenance or due to anything else deemed to be the fault of the user, in particular failure to comply with the instructions for use;
- repairs have been carried out on the product by third parties;
- the defect was caused as the result of an accident.
- the serial number has been damaged or removed

The guarantee makes no provision for any alteration or deterioration to the product that is incurred through normal usage (wear and tear). The period of guarantee shall not be extended by any remedial measures carried out by the manufacturers in the event of a claim.

_ CLEANING INFORMATION

A soft brush or damp cloth is all that is required to remove slight soiling from the CONCORD SCOUT folding carrycot.

_ CONCORD ORIGINAL SPARE PARTS/ACCESSORIES

Information on Concord original spare parts/accessories is available at your retailer's or directly from Concord.

Concord GmbH
Industriestraße 25
95346 Stadtsteinach
Germany

Phone +49 (0)9225.9550-0
Fax +49 (0)9225.9550-55
info@concord.de

www.concord.de

- _ **D** // GEEIGNETE BUGGY-FAHRGESTELLE
- _ **GB** // COMPATIBLE BUGGY CHASSIS
- _ **F** // CHASSIS DE POUSETTES APPROPRIES
- _ **E** // CHASIS DE SILLA DE PASEO ADECUADOS
- _ **I** // TELAI PER PASSEGGINO COMPATIBILI
- _ **P** // CHASSIS DO CARRINHO DE BEBÉ COMPATÍVEIS
- _ **NL** // GESCHIKTE BUGGY-ONDERSTELLEN
- _ **N** // EGNEDE BUGGY-CHASSISER
- _ **DK** // EGNEDE BUGGY CHASSISRAMMER
- _ **FIN** // YHTEENSOPIVA ISTUINRUNKO

- CONCORD **AVENUE**
- CONCORD **CAMINO**
- CONCORD **NEO**
- CONCORD **WANDERER**

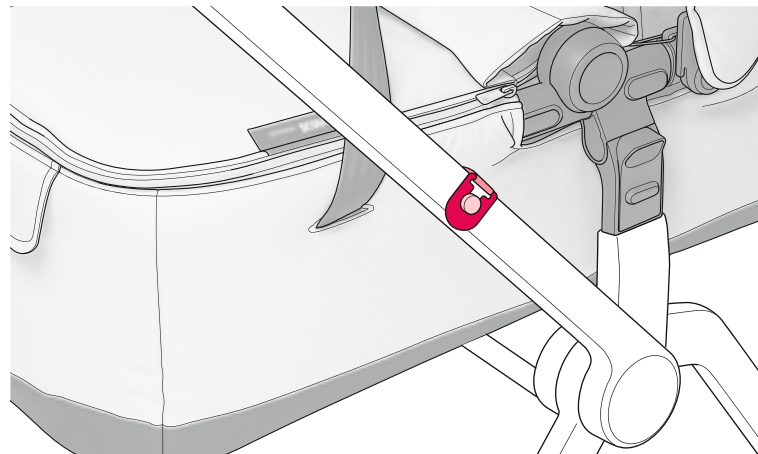

- CONCORD **AVENUE**
- CONCORD **CAMINO**
- CONCORD **FUSION**
- CONCORD **NEO**
- CONCORD **SOUL**
- CONCORD **WANDERER**

_ **DEUTSCH**
_ **ENGLISH**
_ **FRANÇAIS**
_ **ESPAÑOL**
_ **ITALIANO**
_ **PORTUGUÊS**
_ **NEDERLANDS**
_ **NORSK**
_ **DANSK**
_ **SUOMI**

Einbau- und Bedienungsanleitung
Instructions for attachment and use
Directives d'installation et mode d'emploi
Instrucciones de montaje y de uso
Istruzioni per l'uso e il montaggio
Manual de montagem e de utilização
Inbouw- en bedieningshandleiding
Bruksanvisning og monteringsveiledning
Monterings- og betjeningsvejledning
Kiinnitys- ja käyttöohjeet

Concord GmbH
Industriestraße 25
95346 Stadtsteinach
Germany

Phone +49 (0)9225.9550-0
Fax +49 (0)9225.9550-55
info@concord.de

www.concord.de

